

INSTRUCTIONS: MAINTENANCE AND INSPECTIONS

HARMON W C O - 3 2 HOTBOX DETECTOR

- I. Weekly Inspections and Tests performed by Signal Maintainer:
- A. Inspect approach and gating wheel transducer to insure cable plug coupler and mounting bolts are secure.
  - B. Inspect scanners to insure it is properly secured to foundation and no external damage is visible. If track is "pumping", or rail is "running", contact Section Foreman for repair.
  - C. Clean scanner mirror surface and lens with soft cloth.
  - D. Change recorder tape (as required) and send tapes to Signal Inspector's Office for their review.
  - E. Clean recorder pens.
  - F. Verify that radio will transmit and Mars light and indication circuits are operational:
    - 1. Drop short track relay (C T R)
    - 2. Drop H B P Relay
    - 3. Gate System
    - 4. Verify Mars light is on and D S got indication.
    - 5. Pick H B P Relay
    - 6. Pick C T R Relay
    - 7. Listen on truck radio and verify that system is transmitting.
  - G. Watch a train over system and observe normal levels.

II. Monthly Inspection and Tests performed by Signal Maintainers:

A. Perform all weekly tests.

B. Using a digital meter, check supply voltages and record on Monthly Report:

1. 26 V D C: 12 cells of lead battery, 26.4 V  
+/- 0.2 V.
2. 24 V D C: Unregulated W C O - 3 5 Supply,  
24.0 V +/- 4 V.
3. 47 V D C: Regulated W C O - 3 5 Supply,  
47.0 V +/- 1.5 V.
4. + 5 V D C: Regulated (read on test point  
on back of Talker Power  
Supply): 5.0 V D C + 0.2 V to  
- 0.1 V. If not in range,  
adjust.
5. + 12 V D C: Regulated (read on test point)  
+ 12 V +/- 0.4 V.
6. - 12 V D C: Regulated (read on test  
point): - 12 V +/- 0.6 V. Not  
adjustable.
7. 120 V A C: Inverter output.
8. 120 V A C: House power.

C. Calibrate recorder:

1. Set tension on analog pens to 2 grams.
2. Turn Mode Switch on W C O - 3 4 processor to  
Position "D" (Recorder Calibrate).

- 703  
441  
15
3. You will have a 5, 10, 15 and 20 m m pulse shown on the recorder.
  4. Adjust the recorder gains so that the 15 m m pulse is at "15 m m" on the recorder.
  5. Push reset to terminate Recorder Calibrate.
  6. Set time and date on recorder.

D. Check alarm levels:

1. Set Mode Switch to Position "A"
2. Use Function Switch to determine which level you are checking.
  - a. With Function Switch in center position, the display will show the name of the alarm criteria.
  - b. With Function Switch in the right position, the display will show the alarm level.
3. After each alarm criteria is checked, push Data Advance to go to the next alarm setting.
4. If alarm levels are not correct, put analog I O Board on extender socket and adjust levels.

III. Quarterly Inspections and Tests to be performed by Signal Inspector and Signal Maintainer:

- A. Perform all Weekly and Monthly Tests.
- B. Check alignment.
  1. Check position of scanners; on hot journal scanners, scanner should be 6-3/4 inches from gauge to center of scanner opening, 16 inches from center line of scanner to center of "B" transducer, and 1 inch down from top of rail to top of the raised lip on scanner opening.
  2. Check position of scanners, on hot wheel scanners. Scanner should be 11-3/8 inches from gauge to center of scanner, center of scanner opening should be halfway between A & B transducers, top of lip on scanner should be 1-1/8 inch down from top of rail.
  3. Check alignment of hot journal scanners.
    - a. Position alignment fixture on north rail, 26 inches from center of scanner to center of alignment fixture and 6-3/4 inches outside of gauge.
    - b. Turn off DPU power supply
    - c. Open scanner on north rail.
    - d. Remove preamp.
    - e. Install laser.
    - f. Turn on DPU power supply and laser.
    - g. Adjust mirror until red dot is in center of alignment fixture target.
    - h. Install scanner lid.

- i. Place scanner position plug on scanner opening with alignment tube in front end of scanner opening and long tube on top of scanner.
- j. Swing transducer, to start system, and verify laser is centered in alignment tube.
- k. If not, check scanner position as described in III-B-1 and do steps III-B-3-g through i, again.
- l. Do steps III-B-3-a through k, for south rail hot journal scanner.
- m. Position alignment fixture on north rail hot wheel scanner, halfway between A & B transducers.  
  
NOTE: Alignment fixture must be placed inside gauge and use short alignment target, set target in front (closest to gauge) hole.
- n. Do steps III-B-3-b through j.
- o. If not, check scanner position as described in III-B.2 and do steps III-B-3-g through j again.
- p. When through, make sure all preamps are installed, scanner lids are secured, and DPU power is on.

C. Check pre-amp calibration:

1. Plug in Calibrated Heat Source, set for 70<sup>0</sup>C. and allow 15 minutes for system to heat and stabilize.
2. Turn off power, put analog board on extender socket and turn on power.
3. Position heat source on front of scanner on North rail.
4. Put Mode Switch in Position "B" (Chop)
5. Push Data Advance to select Rail 1.
6. Read display and observe output of pre-amp.
7. Output should be 12 mm
8. If outputs are not 12 mm adjust IN5 modules on analog card for 12 mm output.
9. Repeat Steps C.-2. through C.-8. for South rail.
10. Repeat steps C-2 through C-8 for north and south rails of hot wheel scanner.

NOTE: Iris plate must be removed from hot wheel preamp before test and reinstalled when completed.

D. Check differential alarm:

1. Put mode switch in position "E"  
(test gate).
2. Put function switch in position "1"  
and push data advance.
3. Put adjustable heat source on  
alignment fixture, on rail No 1.
4. Adjust heat source and watch recorder  
to verify system will alarm at 9 m m.  
NOTE: System doesn't look at pedistal  
so a 9 differential will fire at 9 m m.
5. Put function switch back to center  
position and listen to readout and  
verify only 4 alarms are given and  
count and side designation are correct.
6. Do steps D-1 through D-5 for rail No 2.

E. Check absolute alarm:

1. Put mode switch in position "E" (test gate).
2. Put function switch in position "1" and  
push data advance.
3. Put adjustable heat source on alignment  
fixture on rail No 1.
4. Put preheated calibrated heat source  
on rail No 2.
5. Adjust heat source and watch recorder  
to verify system will alarm at 18 m m.

- 125
6. Do steps E-1 through E-5 for rail No 2 with calibrated heat source on rail No 2.
  7. Put function switch back to center position and listen to readout.

F. Check hot wheel alarm:

1. Remove aperture washers from hot wheel pre-amps.
2. Put mode switch in position "E" (test gate).
3. Put function switch in position "1" and push data advance.
4. Put adjustable heat source on alignment fixture on north rail hot wheel scanner.
5. Adjust heat source and watch recorder to verify system will alarm at 14 m m.
6. Put function switch back to center position and listen to readout and verify only 4 alarms are given and count and side designation are correct.
7. Do steps F-2 through F-6 for south rail hot wheel scanner.
8. Replace lens aperture washers on hot wheel pre-amps and secure pre-amps and scanner covers.

- G. Turn power off on processor unit and back on to Dump Memory on Data Recall.

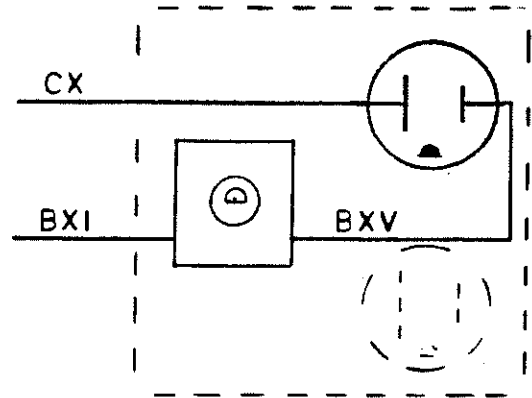
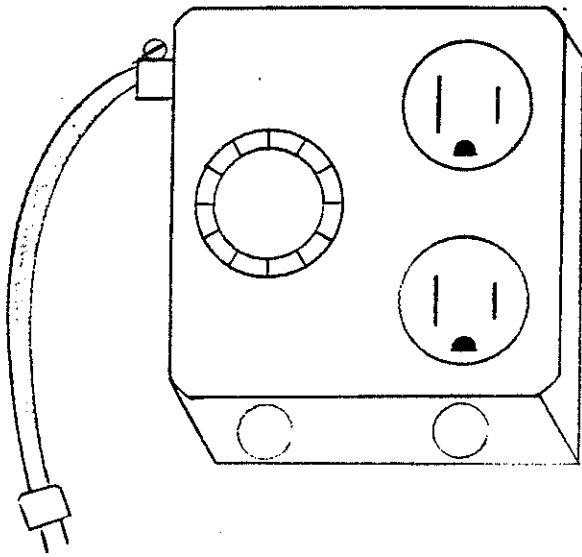

Dimmer switch  
and duplex outlet  
mounted inside of  
4" x4" box.

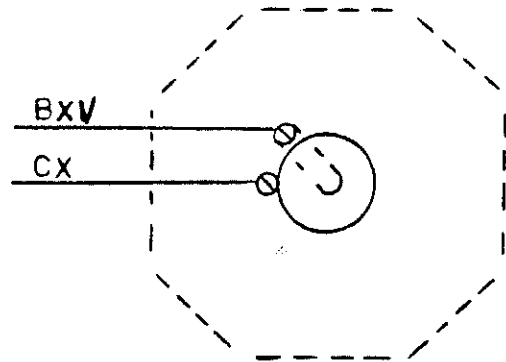
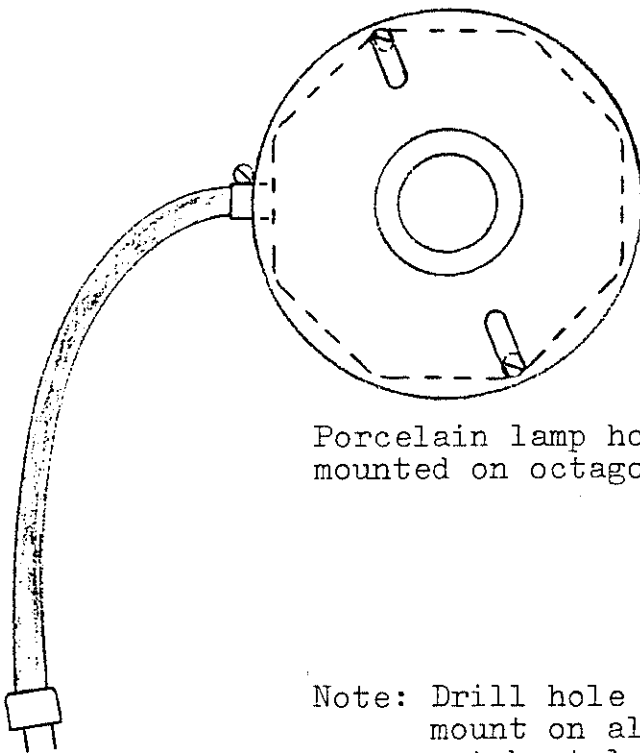

Porcelain lamp holder  
mounted on octagon box.

Note: Drill hole in back of box to  
mount on alignment fixture and  
put heat lamp in socket for  
heat source.

INSTRUCTIONS: MAINTENANCE AND INSPECTIONS

HARMON W C O - 3 2 HOTBOX DETECTOR WITH DCP-2

- I. Weekly Inspections and Tests performed by Signal Maintainer:
  - A. Inspect wheel transducer to insure cable plug coupler and mounting bolts are secure.
  - B. Inspect scanners to insure it is properly secured to mounting saddle and no external damage is visible. If track is "pumping", or rail is "running", contact Section Foreman for repair.
  - C. Clean scanner mirror surface and lens with soft cloth.  
Use anti-fog cleaning solution (Item No. 4724800063)
  - D. In the Display Mode, do an "LD" (List Defects) command.
    1. Use the R# command and review all defect trains that have not been previously dumped.
    2. Send these printouts to Signal Inspector's office.
  - E. Verify that radio will transmit.
    1. Put Mode Switch in position "E".
    2. Push Data ADV (This will start test gating)
    3. After system starts; push Data ADV again (this will stop test gating)
    4. Listen to truck radio on road channel and verify radio could be heard. If not, contact radio man.
  - F. Verify if rotating white light is operational:
    1. Pick CTR Relay
    2. Turn off power on DPU.
    3. Observe Mars light and verify both lights are on, and that light is rotating.
    4. Drop CTR and turn on power on DPU.
  - G. Watch a train over system and observe normal levels on printout of train.

INSTRUCTIONS: MAINTENANCE AND INSPECTIONS  
HARMON WCO-32 HOT BOX DETECTOR

- I. Weekly Inspections and Tests performed by Signal Maintainer:
- A. Inspect wheel transducer to insure cable plug coupler and mounting bolts are secure.
  - B. Inspect scanners to insure it is properly secured to mounting saddle and no external damage is visible. If track is "pumping", or rail is "running", contact Section Foreman for repair.
  - C. Clean scanner mirror surface and lens with soft cloth. Use anti-fog cleaning solution (Item No. 4724800063)
  - D. In the Display Mode, do an "LD" (List Defects) command.
    - 1. Use the R# command and review all defect trains that have not been previously dumped.
    - 2. Send these printouts to Signal Inspector's office.
  - E. Verify that radio will transmit.
    - 1. Put Mode Switch in position "E".
    - 2. Push DATA ADVANCE is will start test gateing)
    - 3. After system starts; push Data ADV again (this will stop test gateing)
    - 4. Listen to truck radio on road channel and verify radio could be heard. If not, contact radio man.
  - F. Verify if rotating white light is operational:
    - 1. Pick CTR Relay
    - 2. Turn off power on DPU.
    - 3. Observe Mars light and verify both lights are on, and that light is rotating.

4. Drop CTR and turn on power on DPU.
  - G. Watch a train over system and observe normal levels on printout of train.
- II. Monthly Inspection and Tests performed by Signal Maintainers:
- A. Perform all weekly tests.
  - B. Using a digital meter, Fluke 8024B or equivalent, check supply voltages and record on Monthly Report:
    1. 27 V D C: 12 cells of lead battery, 27.2 V +/- 0.2 V.
    2. 24 V D C: Unregulated W C O - 3 5 Supply, 24.0 V  
-2.0V to +5.0V

NOTE: If system is Hot Box/Hot Wheel read 24V  
with shutters open.

    3. 47 V D C: Regulated W C O - 3 5 Supply, 47.0 V +/-  
1.5V.
    4. + 5 V D C: Regulated (read on test point on back of  
DPU Power Supply): 5.0 V D C + 0.2 V to - 0.1 V. If  
not in range, adjust.
    5. + 12 V D C: Regulated (read on test point) + 12 V +/-  
0.4V.
    6. - 12 V D C: Regulated (read on test point): - 12 V  
+/- 0.6 V. Not adjustable.
    7. 124 V A C: Invertor output.
    8. 120 V A C: House power.
  - C. Check time and date.
    1. In maintenance mode, enter an "I" command.
    2. If time is not correct, use "T" command to set time.

D. Check alarm levels:

1. In alarm mode, enter "C" command.
2. Levels should be as follows:

a. On Hot Box analog card

<u>Pot</u>	<u>Name</u>	<u>Setting</u>
1.	Not Used	--
2.	High Limit(Absolute)	18.mm
3.	Slope	1.52
4.	CS-Limit	7.0 mm
5.	Wheel Gate	17 inches
6.	Differential	9.0 mm

b. On Hot Wheel analog board

<u>Pot</u>	<u>Name</u>	<u>Setting</u>
1.	Hot Wheel	17 mm

3. If levels are not correct, change as follows:

- a. Set Mode Switch to Position "A"
- b. Use Function Switch to determine which level you are checking.
  - i With Function Switch in center position, the display will show the name of the alarm criteria.
  - ii With Function Switch in the right position, the display will show the alarm level.
- c. After each alarm criteria is checked, push Data Advance to go to the next alarm setting.
- d. If alarm levels are not correct, adjust levels on the analog boards.

NOTE: Anytime the 5V logic level is adjusted on the DPU power supply, the alarm levels must be checked.

III. Quarterly Inspections and Tests to be performed by Signal Inspector and Signal Maintainer:

- A. Perform all Weekly and Monthly Tests.
- B. Check alignment.

- 1. Check position of scanners; on hot journal scanners.

- a. Tie Mounted Scanner

- Scanner should be 6-3/4 inches from gauge to center of scanner opening, 16 inches from center line of scanner to center of "B" transducer, and 1 inch down from top of rail to top of the raised lip-on scanner opening.

- b. Rail Mounted Scanner

- Scanner should be 6-3/4" from gauge to center to scanner opening, and 15" from perpendicular line on scanner to center of "B" transducer.

- 2. Check position of scanners, on hot wheel scanners.

- a. Tie Mounted Scanners

- Scanner should be 11-3/8 inches from gauge to center of scanner, center of scanner opening should be halfway between A & B transducers, top of lip on scanner should be 1-1/8 inch down from top of rail.

- b. Ballast Mounted Scanner

- Scanner should be adjusted to a point in the center of gate (halfway between A & B transducer) and 3 inches above top of rail.

- 3. Check alignment of hot journal scanners, tie mounted.

- a. Position alignment fixture on north rail, 26 inches from center of scanner to center of alignment fixture and 6-3/4 inches outside of gauge.

- b. Turn off DPU power supply

- c. Open scanner on north rail.

- d. Remove preamp.
  - e. Install laser.
  - f. Turn on DPU power supply and laser.
  - g. Adjust mirror until red dot is in center of alignment fixture target.
  - h. Install scanner lid.
  - i. Place scanner position plug on scanner opening with alignment tube in front end of scanner opening and long tube on top of scanner.
  - j. Swing transducer, to start system, and verify laser is centered in alignment tube.
  - k. If not, check scanner position as described in III-B-1 and do steps III-B-3-g through i, again.
  - l. Do steps III-B-3-a through k, for south rail hot journal scanner.
  - m. Position alignment fixture on north rail hot wheel scanner, halfway between A & B transducers.  
NOTE: Alignment fixture must be placed inside gauge and use short alignment target, set target in front (closest to gauge) hole.
  - n. Do steps III-B-3-b through j.
  - o. If not, check scanner position as described in III-B.2 and do steps III-B-3-g through j again.
  - p. When through, make sure all preamps are installed, scanner lids are secured, and DPU power is on.
4. Check alignment of hot journal scanners, rail mounted.
    - a. Position alignment fixture on north rail 23-1/2 inches from perpendicular line on scanner to center of alignment fixture and 6-3/4 inches outside gauge.
    - b. Turn off 12v power supply.

- c. Open scanner on north rail.
- d. Remove preamp.
- e. Install laser.
- f. Turn on 12v power supply and laser.
- g. Adjust scanner until red dot is in center of the alignment fixture target.
- h. Turn off 12v power supply.
- i. Remove the laser and install preamp.
- j. Replace scanner lid.
- k. Do steps III-b-4-a through j for south rail hot journal scanner.

C. Check pre-amp calibration:

1. Plug in Calibrated Heat Source, set for 70°C. and allow 15 minutes for system to heat and stabilize.
2. Position heat source on front of scanner on North rail.
3. Put Mode Switch in Position "B" (Chop)
4. Push Data Advance to select Rail 1.
5. Read display and observe output of pre-amp.
6. Record level on log sheet (should be 15mm - .5mm).
7. Repeat Steps III C.-2. through C.-6. for South rail.
8. Repeat steps III C-2 through C-6 for north and south rails of hot wheel scanner.

NOTE: Iris plate must be removed from hot wheel preamp before test and reinstalled when completed.

D. Verify Alarm

NOTE: Do steps III-E, F. and G only if instructed by supervisor. For regular inspections do as follows.

1. Put Mode Switch in position "Functional Self Test".
2. Push Data Advance.

3. At end of test, print out test train.

4. Verify alarm levels in test train.

E. Check differential alarm:

1. Put mode switch in position "E" (test gate).

2. Push data advance.

NOTE: Test gate will timeout after 1000 axles if not stopped before.

3. Put adjustable heat source, shown on A-215-9, on alignment fixture, on rail No 1.

4. Adjust heat source and watch alarm light on front of DPU.

5. After system has alarmed, push data advance.

6. Print out test train and verify system alarmed at 9 mm.

7. Do steps E-1 through E-6 for rail No. 2.

F. Check absolute alarm:

1. Put mode switch in position "E" (test gate).

2. Push data advance.

3. Put adjustable heat source, shown on A-215-9, on alignment fixture on rail No 1.

4. Put preheated calibrated heat source on rail No 2.

5. Adjust heat source and watch alarm light on front of DPU.

6. After system has alarmed, push data advance.

7. Printout test train and verify system alarmed at 18 mm.

8. Do steps F-1 through F-7 for rail No. 2 with adjustable heat source on rail No. 2, and calibrated heat source on rail No. 1.

G. Check hot wheel alarm:

1. Remove aperture washers from hot wheel pre-amps.

2. Put mode switch in position "E" (test gate).

3. Push data advance.

4. Put adjustable heat source on alignment fixture on north rail hot wheel scanner.
5. Adjust heat source and watch alarm light on front of DPU.
6. After system has alarmed, push data advance.
7. Print out test train and verify system alarmed at 17 mm.
8. Do steps G-2 through G-7 for south rail hot wheel scanner.
9. Replace lens aperture washers on hot wheel pre-amps and secure pre-amps and scanner covers.

H A R M O N   H O T B O X   D E T E C T O R   I N S P E C T I O N   R E C O R D

(to be sent to Signal Supervisor, Signal Engineer and Dir. Sig System: M o n t h l y)

Name of Location: \_\_\_\_\_ Division: \_\_\_\_\_

Subdivision: \_\_\_\_\_ Milepost: \_\_\_\_\_

Month: \_\_\_\_\_ Name: \_\_\_\_\_

W E E K L Y   I N S P E C T I O N S

	Week 1	Week 2	Week 3	Week 4	Week 5
Inspect Transducers					
Inspect Scanner					
Clean Mirror and Scanner Lens					
Check Radio, Mars Light					
Watch Train & Observe Normal Levels					
Date and Initials					

M O N T H L Y   I N S P E C T I O N S

	TYPICAL LEVELS	F O U N D	L E F T
27 V D C (Battery)	27.2 (+/- 0.2)		
24 V D C	24.0 (+/- 4)		
47 V D C	47.0 (+/- 1.5)		
+ 5 V D C	5.0 (+ 0.2 to - 0.1)		
+ 12 V D C	12.0 (+/- 0.4)		
- 12 V D C	- 12.0 (+/- 0.6)		
120 VAC (Inverter)	124		
120 VAC(House Power)	120		
Check Alarm Levels:	Yes		
High Limit	18		
C S Ratio	1.52		
C S Limit	7		
W H L Gate	17		
Diff	9		
Hot Wheel	17		

List repairs made during month:

---



---



---

H A R M O N   H O T B O X   D E T E C T O R   Q U A R T E R L Y  
I N S P E C T I O N   R E C O R D

(Send to Signal Supervisor, Signal Engineer and Dir. Sig System upon completion)

Name of Location: \_\_\_\_\_ Division: \_\_\_\_\_  
 Subdivision: \_\_\_\_\_ Milepost: \_\_\_\_\_  
 Date: \_\_\_\_\_ Name: \_\_\_\_\_

Q U A R T E R L Y   I N S P E C T I O N S

	Typical Levels	Found	Left
Check Alignment	6-3/4" x 24-1/2"		
Check Pre-Amp Calibration (HB)	12 m m	NR	NR
		SR	SR
Check Pre-Amp Calibration (HW)	12 m m	NR	NR
		SR	SR
Differential Alarm	9 m m		
Absolute Alarm	18 m m		
Hot Wheel Alarm	17 m m		
Verify alarms and Count for	Yes		
Four (4) Hotboxes	Okay		
Four (4) Hotwheels	Yes		
Two (2) Dragging Equipment	Okay		
One (1) Shifted Load	N A		